

General Information

The HFA evaluation fixture is a special purpose board which frees users from the time-consuming task of developing their own evaluation hardware. It also serves as an example of the type of high frequency layout required by ultra high speed op amps. The board makes no provision for easy modification to other configurations. Modifications are strongly discouraged, since surface mount printed circuit pads tend to disintegrate after only a few resolderings.

The fixture is wired in a gain of +2 as shown in Figure 1. It is intended for use in a 50Ω environment, so input and output termination resistors have been incorporated. Figure 2 illustrates the typical frequency response of an HFA1100/30 in this fixture.

Evaluating the HFA1100

As delivered, the fixture is ideal for evaluating the HFA1100. The V_H and V_L connections have no effect, since pins 5 and 8 are not bonded out on the HFA1100. Figure 3 details a setup for evaluating the amplifier's pulse response, while Figure 4 illustrates the HFA1100 performance in this setup. The scope input trace accurately reflects the amplifier input, but the output trace is one-half the amplifier output voltage.

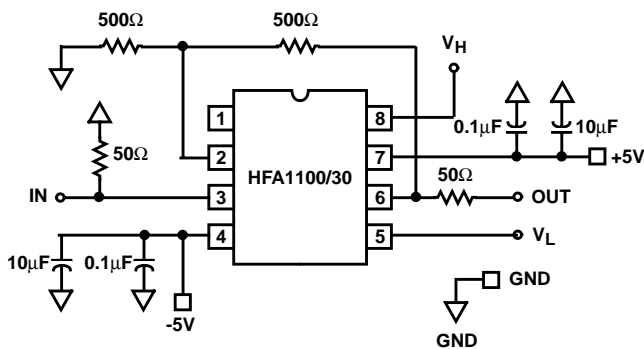

FIGURE 1. SCHEMATIC OF HFA1100/30 EVALUATION BOARD

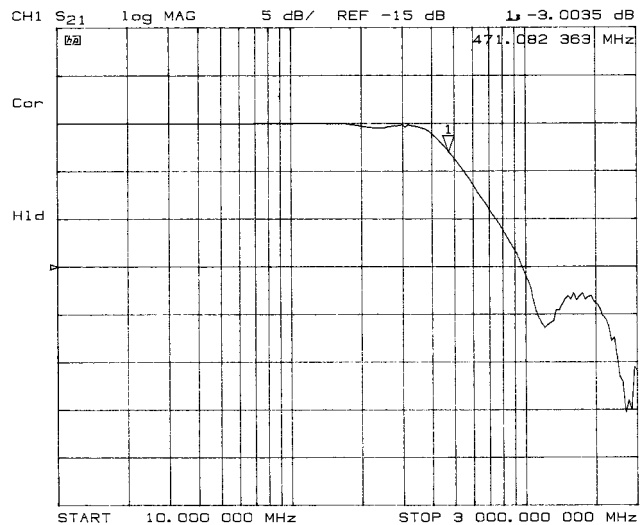

FIGURE 2. HFA1100/30 FREQUENCY RESPONSE ($A_V = +2$)

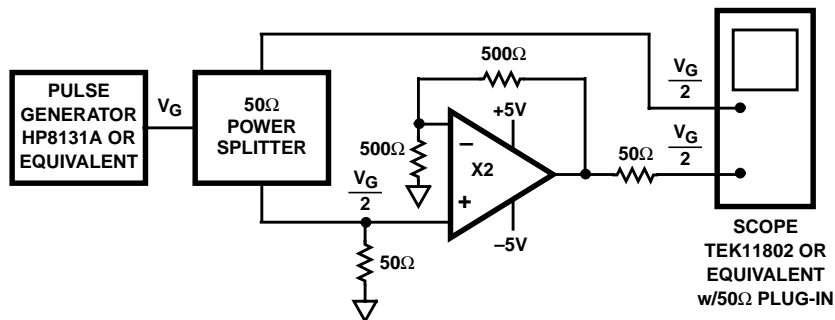

FIGURE 3. CONNECTION FOR EVALUATING HFA1100 PULSE RESPONSE

Evaluating the HFA1120

This fixture is not recommended for evaluation of the HFA1120. The HFA1120 incorporates balance pins (pins 1 and 5) which are absent on the HFA1100. Pin 1 is unconnected on this fixture, while pin 5 is connected to the V_L terminal. The unequal capacitance on these pins may unbalance the amplifier and prevent any meaningful evaluation.

Evaluating the HFA1130

No fixture modifications are necessary when evaluating the HFA1130. When evaluating unclamped performance, the V_H and V_L inputs may be left floating. An unclamped HFA1130 performs like an HFA1100/20 in that the output is clamped to a default value of approximately $\pm 4.2V$. Even though the output swing is less than $\pm 4.2V$, the default clamp provides fast overdrive recovery on the HFA11XX family.

Figure 5 illustrates the HFA1130 clamped pulse response for a positive pulse. The set-up for evaluating the clamped overdrive recovery time is detailed in Figure 6. This set-up uses a slower pulse generator, since input transitions $\geq 2ns$ yield the best results.

INPUT AND OUTPUT: 100mV/DIV

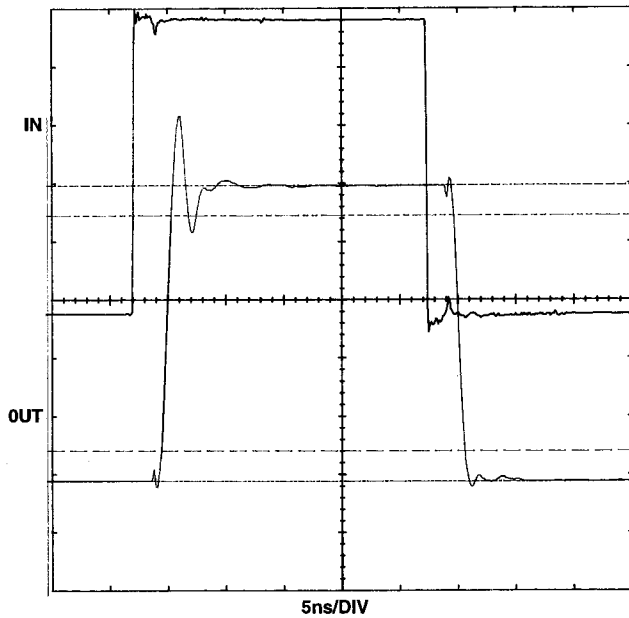

FIGURE 4. HFA1100 PULSE RESPONSE

INPUT: 200mV/DIV

OUTPUT: 100mV/DIV

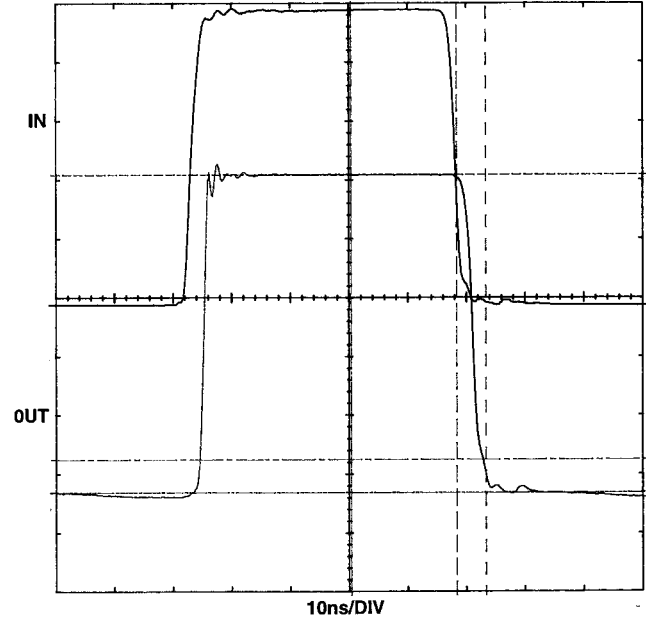

FIGURE 5. HFA1130 CLAMPED PULSE RESPONSE

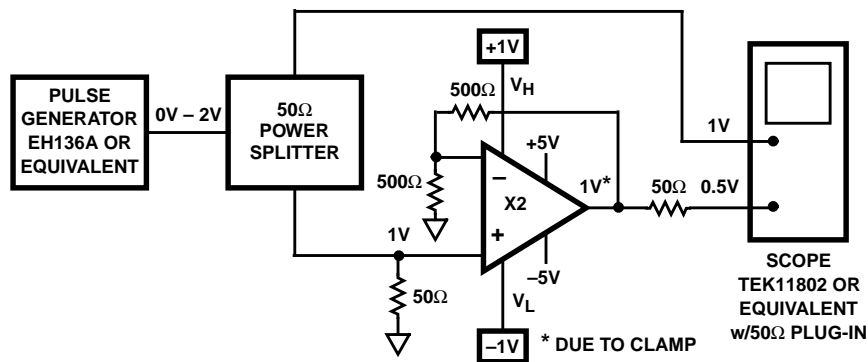

FIGURE 6. CONNECTION FOR EVALUATING HFA1130 OVERDRIVE RECOVERY

All Intersil semiconductor products are manufactured, assembled and tested under **ISO9000** quality systems certification.

Intersil semiconductor products are sold by description only. Intersil Corporation reserves the right to make changes in circuit design and/or specifications at any time without notice. Accordingly, the reader is cautioned to verify that data sheets are current before placing orders. Information furnished by Intersil is believed to be accurate and reliable. However, no responsibility is assumed by Intersil or its subsidiaries for its use; nor for any infringements of patents or other rights of third parties which may result from its use. No license is granted by implication or otherwise under any patent or patent rights of Intersil or its subsidiaries.

For information regarding Intersil Corporation and its products, see web site <http://www.intersil.com>